

High oxide ion conduction in sintered Bi_2O_3 containing SrO, CaO or La_2O_3

T. TAKAHASHI, H. IWAHARA and Y. NAGAI

Department of Applied Chemistry, Faculty of Engineering, Nagoya University, Nagoya, Japan

Received 16 September 1971

Ionic conduction in sintered oxides of the system Bi_2O_3 -SrO was investigated by measuring the conductivity and ion transference number under various conditions. The ion transference numbers were measured by an oxygen concentration cell employing the specimen as the electrolyte.

It was found that the solid solution containing 20~40 mole% SrO which had a rhombohedral structure was an almost pure oxide ion conductor under a relatively high partial pressure of oxygen, and that the conductivity was several times higher than that of stabilized zirconias at the same temperatures up to 800°C. Oxide ion conduction was confirmed also by quantitative determination of generated O_2 from the anode of the oxygen concentration cell during discharge.

The sintered specimens of the systems Bi_2O_3 -CaO and Bi_2O_3 - La_2O_3 were found also to be oxide ion conductors, and the ion transference numbers were greater than 0.9.

Introduction

A number of references on the electrical properties of solid electrolytes are quoted in a recent review [1]. Highly conductive pure oxide ion conductors studied so far, however, are mainly the fluorite-type solid solutions based on the oxides of tetra-valent metals containing lower valent metallic oxides. In these materials, relatively large amounts of oxide ion vacancies are present in the crystal lattice so as to maintain the electrical neutrality of the crystal, and as a result, they show high oxide ion conduction at high temperature since the vacancies can make the migration of the oxide ions easier [2, 3]. However, high oxide ion conductive materials are considered not to be always limited to the fluorite-type oxide solid solutions of tetra-valent metals. In fact the present authors have found that when Ti in perovskite-type oxide CaTiO_3 was partially substituted by Al or Mg, this oxide showed high oxide ion conductivity comparable to those of the stabilized zirconias [4, 5, 6]. From this result, it is likely that more excellent oxide ion conductors will be discovered if many more oxides of various

types are investigated with respect to their electrical properties.

In the course of investigations with such an aim in mind, the authors observed that the sintered oxides which consisted of Bi_2O_3 and SrO had high oxide ion conductivity even at relatively low temperature. According to L. G. Sillén [7], the Bi_2O_3 -SrO system forms rhombohedral solid solutions in the composition range between 20 and 45 mole% SrO which contains 2.4~5.4 of oxide ion vacancies per 18 lattice sites of oxide ion in the unit cell. However, the investigation on the electrical conduction in this material has not been carried out so far, except in the work by A. D. Neuimin *et al.* [8], in which $(\text{Bi}_2\text{O}_3)_{0.8}(\text{SrO})_{0.2}$ was reported to have oxide ion conduction accompanied by considerable electronic conduction at 400~650°C. According to our experiments, however, this material is predominantly an oxide ion conductor in ordinary atmospheres and the conductivity is higher than that reported by A. D. Neuimin.

In this paper, the results of our experiments over the wide composition range and under various conditions on ionic conduction in the

Bi_2O_3 -SrO system are described. In addition, the existence of ionic conduction in the Bi_2O_3 -CaO and Bi_2O_3 - La_2O_3 systems which contain a phase of rhombohedral crystal structure, as in the case of the Bi_2O_3 -SrO system, was studied in a preliminary way and the results are briefly described.

Experimental

Preparation of the specimens

The starting materials were strontium nitrate (JIS special grade) and bismuth sesqui-oxide which was obtained by thermal decomposition of bismuth nitrate (JIS special grade) at 700°C for 2 hours. In place of strontium nitrate, calcium carbonate, lanthanum oxide or cadmium nitrate were also used. The mixture of these substances was heated to decompose the nitrate or carbonate in order to obtain mixed oxide and calcined at $700\sim 800^\circ\text{C}$ for 10 hours in air. The calcined materials were finely powdered before pressure moulding into a column ($0.6^\phi \times 0.5\sim 1.0$ cm) or tablet ($1.2^\phi \times 0.1\sim 0.3$ cm) at $3\sim 4$ ton/cm² and sintered in air for 10 hours. The sintering temperature was changed from 800°C to 1000°C according to the compositions. The greater the content of doped oxide, the higher the sintering temperature.

Measurement of ionic conduction

The ionic conduction in the specimens was examined under various conditions by measuring the electrical conductivity and the emf of the oxygen concentration cell using the specimen tablet as the electrolyte. The emf measurement was employed to determine ion transference numbers.

The measurement of conductivity was made by means of an A. C. bridge incorporating a capacity compensator. The column-shaped specimen was used in this case and silver or platinum paste was applied to the electrode. The value of conductivity varied with the frequency of the current passed, but as it became almost constant in the frequency ranges higher than 5 kHz, 5 kHz was used in this experiment.

The relative contributions of ions and electrons

to the total conductivity were measured by the concentration cell method. The following cell was constructed using the specimen tablet as the electrolyte.

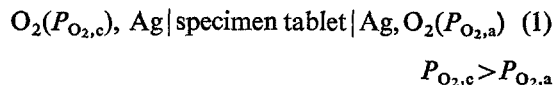

If the conduction in the specimen is purely ionic, the emf of the cell E_0 is given by

$$E_0 = \frac{RT}{4F} \ln \frac{P_{\text{O}_2,c}}{P_{\text{O}_2,a}} \quad (2)$$

where $P_{\text{O}_2,c}$ and $P_{\text{O}_2,a}$ represent the oxygen partial pressures at the cathode and anode respectively, and R , T and F have their ordinary meanings. In the mixed conductor where the conduction is partially ionic and partially electronic, the emf is lowered since the cell is discharged by the electronic conduction. Then the ratio of ionic conductivity to the total conductivity $\sigma = \sigma_i + \sigma_e$ (where σ_e is electronic conductivity), that is, the ion transference number t , can be determined as a ratio of the measured emf E to the theoretical value E_0 [9]

$$t = \frac{\sigma_i}{\sigma_i + \sigma_e} = \frac{E}{E_0} \quad (3)$$

when the electrode reaction is reversible.

In the present experiment, pure oxygen at 1 atm. was used as cathode gas. As anode gas, air free from H_2O and CO_2 was usually applied and the mixture of oxygen and nitrogen or CO and CO_2 was occasionally used to provide for a certain partial pressure of oxygen. Fig. 1 shows the construction of the cell.

Ionic conduction was also ascertained by determining the anodically produced oxygen during the discharge of the concentration cell.

Results and discussion

The prepared specimens

As the specimens were well sintered, the porosities were $5\sim 8\%$ and open pores which allow the penetration of gases were not detected. The porosity was determined by measuring the apparent density of the sintered material and the pycnometric density of the corresponding powder. The

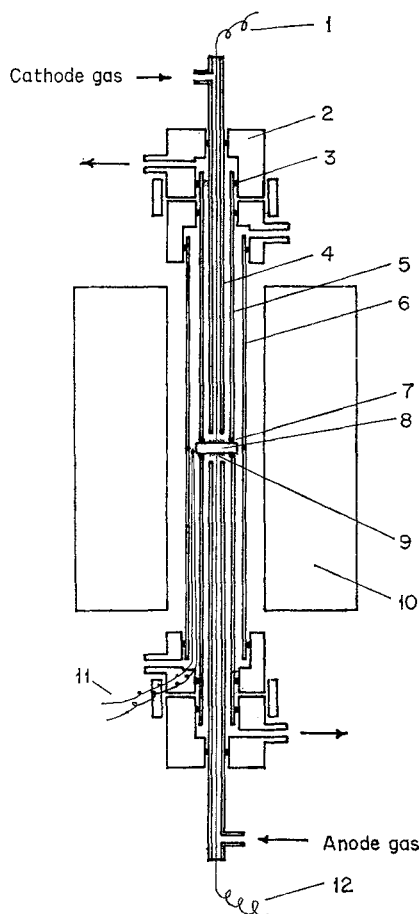

Fig. 1. Construction of the oxygen concentration cell. 1. Pt wire from cathode. 2. Ceramic tube supporter. 3. O-ring packing. 4. Ceramic tube (internal dia. 4 mm). 5. Ceramic tube (internal dia. 9 mm). 6. Ceramic tube internal dia. 23 mm). 7. Pt packing. 8. Electrolyte. 9. Electrode. 10. Hinged electric furnace. 11. Thermocouple. 12. Pt wire from anode.

colour of the sintered specimens changed from yellow to brown as the content of the oxides added to Bi_2O_3 increased.

Fig. 2. represents the X-ray diffraction patterns of the Bi_2O_3 -SrO system. These patterns were obtained by the powder method at room temperature using $\text{CuK}\alpha$ radiation. Pure Bi_2O_3 exhibits a monoclinic pattern of the α -type, while the specimens containing 20~40 mole% SrO evidence the formation of solid solutions having a rhombohedral structure in accordance with the results obtained by L. G. Sillén [7]. In the specimens containing SrO at concentrations greater than 50 mole% the measured diffraction patterns

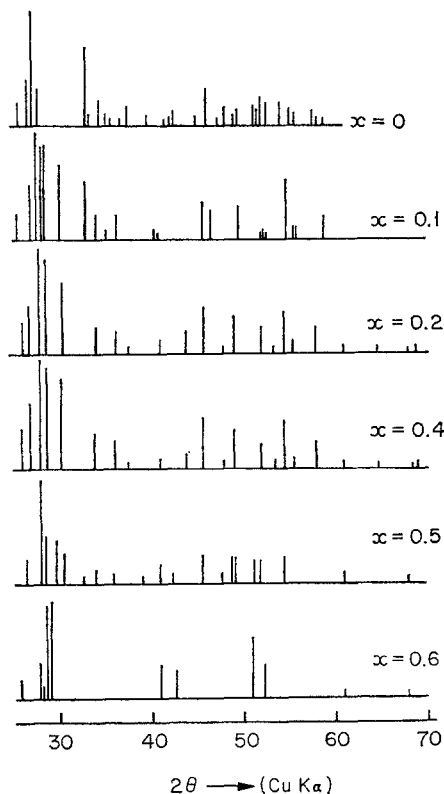

Fig. 2. X-ray diffraction patterns of $(\text{Bi}_2\text{O}_3)_{1-x}(\text{SrO})_x$.

were rather simple although their crystal structures could not be identified.

Ionic conduction in the Bi_2O_3 -SrO system

The conductivities of the sintered Bi_2O_3 -SrO system measured in air are shown in Fig. 3 in the form of Arrhenius plots. It is apparent from this result that the maximum value of conductivity appears in the range of 20~40 mole% SrO, where the change of conductivity with composition is not so marked as in other content ranges. This composition range corresponds to the solid solution having a rhombohedral structure as shown in Fig. 2. The conductivities of $(\text{Bi}_2\text{O}_3)_{0.8}(\text{SrO})_{0.2}$ in air are $6 \times 10^{-3} \text{ ohm}^{-1} \text{ cm}^{-1}$ at 500°C , $2.5 \times 10^{-2} \text{ ohm}^{-1} \text{ cm}^{-1}$ at 600°C and $2.2 \times 10^{-1} \text{ ohm}^{-1} \text{ cm}^{-1}$ at 700°C which are about 4-5 times higher than those reported by previous investigators [8]. The difference may be due to the method of preparation of specimens. Neuminin *et al.* [8] sintered the mixed powder of bismuth oxide and strontium oxide directly at relatively

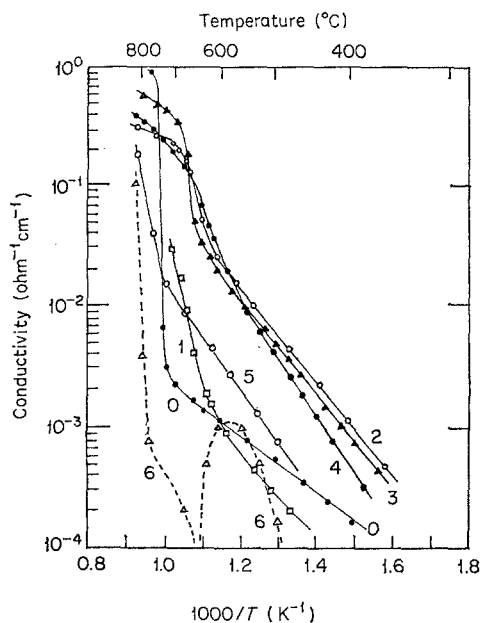

Fig. 3. Electrical conductivities of $(\text{Bi}_2\text{O}_3)_{1-x}(\text{SrO})_x$ in air

No.	x	No.	x
0	0	4	0.4
1	0.1	5	0.5
2	0.2	6	0.6
3	0.3		

low temperatures of $720\sim 750^\circ\text{C}$, and it was confirmed in our experiment that such a preparation method made the conductivity decrease considerably.

The rapid change in conductivity of pure Bi_2O_3 at about 730°C corresponds to the transformation from a monoclinic to cubic crystal structure as pointed out by C. N. R. Rao *et al.* [10]. Though a somewhat remarkable change in conductivity was observed also in the rhombohedral solid solution specimen at $620\sim 670^\circ\text{C}$, no transformation of crystal structure could be recognized by high-temperature X-ray diffractions which were examined at 400°C and 750°C . The differential thermal analysis indicated, however, a small endothermic peak at $620\sim 670^\circ\text{C}$ during the heating process. Thermal hysteresis of the conductivity was not observed in this temperature range and the reproducibility during the heating and cooling processes was good within the experimental error. Furthermore, even after the specimens containing 20 and 40 mole% SrO were kept for 24 hours at 650°C where the de-

pendence of conductivity on temperature was most remarkable, their values of conductivity were observed not to vary from the initial values. It may be considered from these facts that these phenomena may be attributed to a reversible order-disorder transition in the crystal. The details are now under investigation.

In the specimens containing more than 50 mole% SrO, the conductivities decreased with increasing content of SrO, and in the specimen containing 60 mole% SrO the conductivity versus temperature plot indicated an abnormal behaviour showing a minimum value at about 650°C .

Fig. 4 represents the ratio of measured emf to

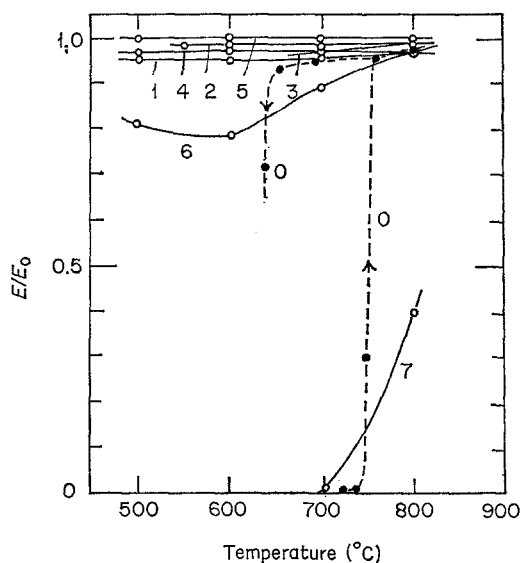

Fig. 4. The ratios of the measured emf E to the theoretical value E_0 of the following cell

O_2 (0.21 atm.), $\text{Ag} | (\text{Bi}_2\text{O}_3)_{1-x}(\text{SrO})_x | \text{Ag}, \text{O}_2$ (1 atm.)

No.	x	No.	x
0	0.0	4	0.4
1	0.1	5	0.5
2	0.2	6	0.6
3	0.3	7	0.7

the theoretical value of the oxygen concentration cell, the electrolyte of which is the sintered tablet of the Bi_2O_3 -SrO system under the conditions of $P_{\text{O}_2,a} = 0.21$ atm and $P_{\text{O}_2,c} = 1$ atm. In the specimens containing 10~50 mole% SrO, the ratio of E to E_0 is higher than 0.9 over a wide range of temperatures. This means that the conduction is mainly ionic which differs from the result of the previous work [8], in which the ion

transference number of $(\text{Bi}_2\text{O}_3)_{0.8}(\text{SrO})_{0.2}$ was determined as $0.50 \sim 0.68$ at $500 \sim 600^\circ\text{C}$ under the same conditions as the present measurements. From the present results, the conductivities shown in Fig. 3 may be concluded to represent the ionic conduction within the SrO content ranges of $10 \sim 50$ mole%.

In the cell using pure Bi_2O_3 as the electrolyte, the emf was not observed up to 730°C . At 730°C the emf appeared and increased suddenly to the theoretical value. This temperature is in accordance with the temperature where the jump in conductivity appears and, therefore, it corresponds to the monoclinic-cubic transformation temperature. During cooling process E/E_0 remains at a higher value than 0.9 down to 640°C where it decreases rapidly. This temperature corresponds to the transition point from the cubic to the metastable tetragonal structure.

These results mean that pure Bi_2O_3 in the monoclinic phase is an electronic conductor and the stable ionic conduction appears after the transition to the cubic phase occurs at 730°C as suggested by the previous investigators [11, 12], whereas it is evident that the SrO doped solid solutions having a rhombohedral structure are almost completely ionic conductors even at 500°C and their conductivities are about one or two orders of magnitude higher than those of pure Bi_2O_3 at temperatures lower than 700°C .

The contribution of ionic conduction to the total conductivity in the solid solution decreased with decreasing partial pressure of oxygen of the surroundings. Fig. 5 shows the dependence of E/E_0 on the partial pressure of oxygen ($P_{\text{O}_2, \text{a}}$) at the anode of the concentration cell, keeping the oxygen pressure at the cathode at 1 atm. The value E/E_0 was decreased rapidly from 0.97 at $P_{\text{O}_2, \text{a}} = 10^{-2}$ atm to 0.5 at $P_{\text{O}_2, \text{a}} = 10^{-6}$ atm. This phenomenon is considered to be due to the reduction of the host crystal under low partial pressure of oxygen, as a result, the excess electrons produced contribute to the electronic conduction.

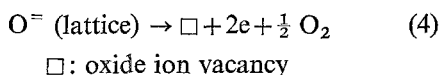

In fact, under hydrogen atmosphere, all specimens investigated were reduced to lower oxides or metals and melted even at 600°C .

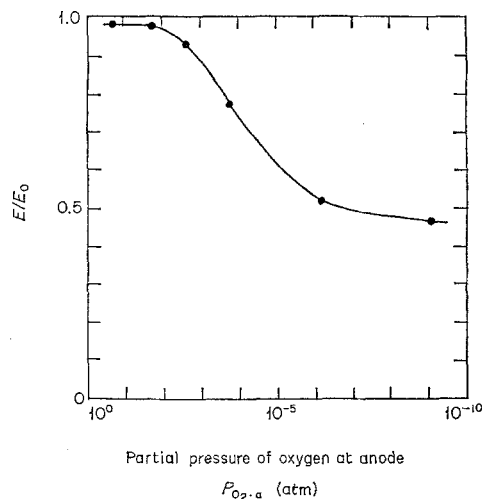

Fig. 5. The dependence of E/E_0 on the oxygen partial pressure of the anode gas in the following cell at 700°C $\text{O}_2 (P_{\text{O}_2, \text{c}}), \text{Ag} | (\text{Bi}_2\text{O}_3)_{0.7}(\text{SrO})_{0.3} | \text{Ag}, \text{O}_2 (1 \text{ atm.})$.

A high current could be drawn from the concentration cell using the Bi_2O_3 -SrO solid solution as the electrolyte. Two examples of the relation between the terminal voltage and current density are represented in Fig. 6. The curves

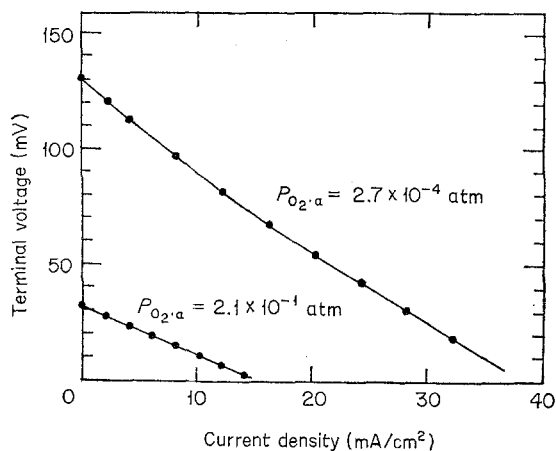

Fig. 6. The discharge curves of the following cell at 700°C $\text{O}_2 (P_{\text{O}_2, \text{c}}), \text{Ag} | (\text{Bi}_2\text{O}_3)_{0.7}(\text{SrO})_{0.3} | \text{Ag}, \text{O}_2 (1 \text{ atm.})$.

were reproducible even after the cell had been short-circuited for a long time. These results indicate that the ion which contributes to conduction is the oxide ion. For, if the cations were charge carriers, a marked polarization should appear and a high current density could not be drawn in a stable manner from the cell.

In order to elucidate the oxide ion conduction and oxide ion transference number more directly, the concentration cell was discharged and the oxygen gas generated at the anode was determined quantitatively by measuring the emf of an oxygen-meter which was an oxygen concentration cell using stabilized zirconia as the electrolyte. As schematically illustrated in Fig. 7, the

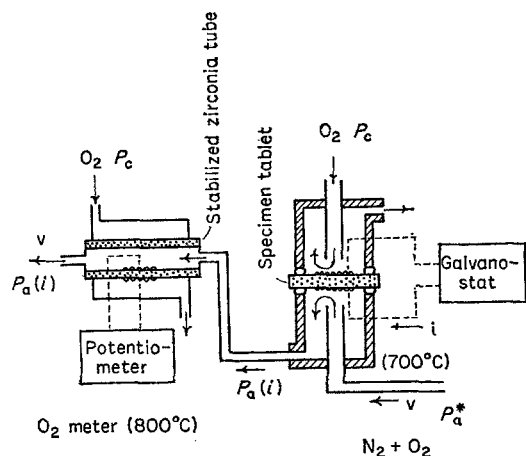

Fig. 7. Schematic illustration of the discharge experiment.

anode gas at relatively low partial pressure of oxygen is passed through the anode compartment of a test cell at a constant flow rate. When the cell is discharged, the generated oxygen gas is mixed with the anode gas and it is led to the anode compartment of the oxygen-meter. If the examined electrolyte is an oxide ion conductor, the emf of the oxygen-meter depends upon the discharge current of the test cell. The relation between the emf of the oxygen-meter E' and the discharge current i of the test cell is given by the following equation,

$$E' = \frac{RT}{4F} \ln \frac{P_c}{P_{a(i)}} \\ = \frac{RT}{4F} \ln \frac{vP_c}{vP_{a(i=0)} + (Vi/4F)i} \quad (5)$$

where t is the oxide ion transference number, P_c the oxygen partial pressure at the cathode of both cells, $P_{a(i)}$ the oxygen partial pressure at the anode of the test cell which depends on discharge current, v the flow rate of the anode gas and V the molar volume of O_2 . From Equation (5), the

ion transference number can be obtained if the values of E' and i are measured.

This experiment was tried using the sintered tablet containing 30 mole% SrO as the electrolyte of the test cell. A mixture of oxygen and nitrogen gas was used as the initial anode gas, its partial pressure of oxygen being 1.51×10^{-4} atm and its flow rate being 2.1 ml/sec. The result is represented in Fig. 8, in which the measured

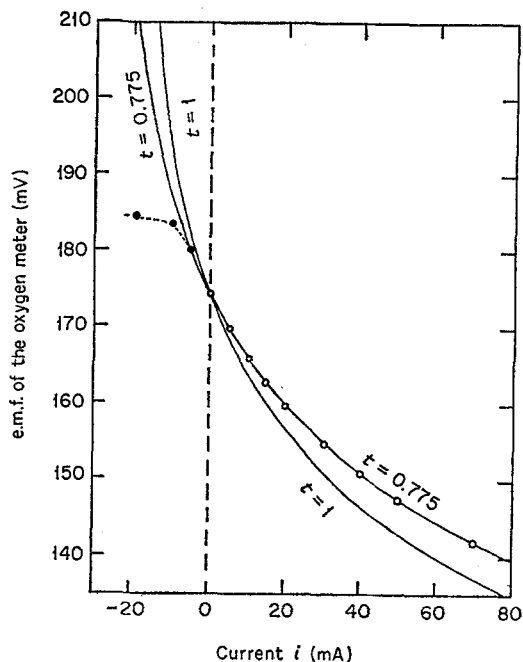

Fig. 8. The plots of the emf of the oxygen meter against the discharge current of the tested cell. Solid lines indicate the theoretical plots for $t = 1.00$ and $t = 0.775$.

values are shown with open circles and the solid lines indicate the theoretical curves of Equation (5) for $t = 1$ and $t = 0.775$ respectively. The measured points coincide well with the calculated curve assuming that the oxide ion transference number is 0.775. This value of transference number agrees with that obtained by the concentration cell method already shown in Fig. 5 under the same atmosphere as this experiment. As a result, it is evident that the ionic conduction in the specimen is due to the oxide ion conduction and that the oxide ion transference numbers measured by the concentration cell method give almost the correct values.

In this experiment, when the current was

passed in the opposite direction, so as to remove oxygen from the anode gas, the measured points shifted markedly from the calculated curve, as shown in Fig. 8 with the closed circles. This fact indicates that electrolysis of the specimen occurs. The decomposition voltage was estimated to be about 500 mV under this condition.

It can be concluded from our experiments, that the solid solution $(\text{Bi}_2\text{O}_3)_{1-x}(\text{SrO})_x$ ($x = 0.2 \sim 0.4$) is an oxide ion conductor at relatively high partial pressures of oxygen. In Fig. 9, known conductivities of oxide ion con-

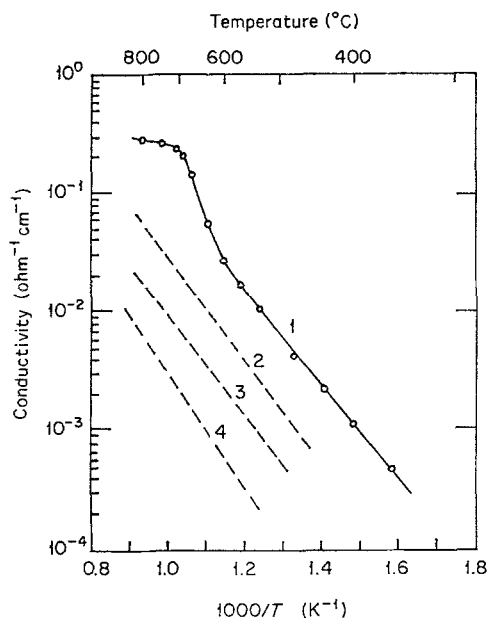

Fig. 9. Comparison of the electrical conductivities of the oxide ion conductors of various types

1. $(\text{Bi}_2\text{O}_3)_{0.8}(\text{SrO})_{0.2}$
2. $(\text{ZrO}_2)_{0.92}(\text{Yb}_2\text{O}_3)_{0.08}$ Reference [13]
3. $(\text{CeO}_2)_{0.8}(\text{LaO}_{1.5})_{0.2}$ Reference [14]
 $(\text{ZrO}_2)_{0.91}(\text{Y}_2\text{O}_3)_{0.09}$ Reference [13]
4. $\text{CaTi}_{0.75}\text{Al}_{0.25}\text{O}_{3-\alpha}$ Reference [4].

ductors are shown in comparison with that of $(\text{Bi}_2\text{O}_3)_{0.8}(\text{SrO})_{0.2}$. This material has the highest conductivity among them in the whole range of temperature below 800°C.

Ionic conduction in sintered Bi_2O_3 containing other oxides

Fig. 10 shows the conductivities of some other systems containing Bi_2O_3 as host material. The measurements were carried out in air. Table 1 is

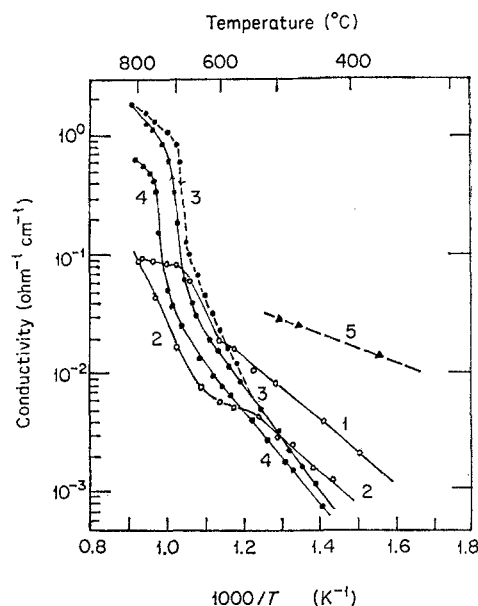

Fig. 10. Electrical conductivities of the sintered Bi_2O_3 containing various kinds of other oxides in air

1. $(\text{Bi}_2\text{O}_3)_{0.9}(\text{La}_2\text{O}_3)_{0.1}$
2. $(\text{Bi}_2\text{O}_3)_{0.7}(\text{La}_2\text{O}_3)_{0.3}$
3. $(\text{Bi}_2\text{O}_3)_{0.8}(\text{CaO})_{0.2}$
4. $(\text{Bi}_2\text{O}_3)_{0.6}(\text{CaO})_{0.4}$
5. $(\text{Bi}_2\text{O}_3)_{0.6}(\text{CdO})_{0.4}$.

Table 1. The ratios of the measured emf E to the theoretical value E_0 of the following cell.

O_2 , (0.21 atm.) $\text{Ag}|\text{Specimen}|\text{Ag}, \text{O}_2$ (1 atm.)

Specimen	E/E_0			
	550°C	600°C	700°C	750°C
$(\text{Bi}_2\text{O}_3)_{0.9}(\text{La}_2\text{O}_3)_{0.1}$	0.92	0.91	0.95	0.95
$(\text{Bi}_2\text{O}_3)_{0.7}(\text{La}_2\text{O}_3)_{0.3}$	0.97	0.95	0.93	0.95
$(\text{Bi}_2\text{O}_3)_{0.8}(\text{CaO})_{0.2}$	0.99	0.97	0.95	
$(\text{Bi}_2\text{O}_3)_{0.6}(\text{CaO})_{0.4}$	0.92	0.93	0.93	0.95
$(\text{Bi}_2\text{O}_3)_{0.6}(\text{CdO})_{0.4}$	0.0 (500°C)			

the E/E_0 value measured by the concentration cell under the condition of $P_{\text{O}_2, a} = 0.21$ atm. and $P_{\text{O}_2, c} = 1.0$ atm. The specimens containing CaO or La_2O_3 show a value higher than 0.9 over a wide temperature range. In these cases, the ion which contributed to conduction was proved to be oxide ion by the same method as described above.

The conductivity versus temperature plots of the Bi_2O_3 - CaO system seem to have a similar

shape to those of the $\text{Bi}_2\text{O}_3\text{-SrO}$ solid solution, though below 700°C their values are somewhat low compared with those of the $\text{Bi}_2\text{O}_3\text{-SrO}$ system and rapid jumps in conductivity at about 700°C are more marked. In the case of $(\text{Bi}_2\text{O}_3)_{0.8}(\text{CaO})_{0.2}$, this temperature corresponds to that of the phase transition from rhombohedral solid solution (s.s.) + monoclinic s.s. to rhombohedral s.s. + cubic s.s. according to the phase diagram proposed by E. M. Levin [15]. Thermal hysteresis was observed in this case, as illustrated by the dotted line in Fig. 10, while this phenomenon was not observed in the specimen containing CaO higher than 30 mole%.

In the specimens containing La_2O_3 the conductivities at high temperature are not so high. In the case of $(\text{Bi}_2\text{O}_3)_{0.9}(\text{La}_2\text{O}_3)_{0.1}$, however, the values at relatively low temperatures are somewhat higher than those of the other kinds of oxide ion conductors. This specimen also has a mixed phase of monoclinic s.s. and rhombohedral s.s. according to the phase diagram [15].

Although the addition of a relatively large amount of La_2O_3 to CeO_2 , which is a fluorite-type oxide, prevents the partial reduction of CeO_2 as previously reported [14], this effect could not be observed in the case of Bi_2O_3 . Bi_2O_3 in the specimen was reduced even under a nitrogen atmosphere at 800°C and the colour changed from yellow to black.

For the sake of comparison, a cadmium-doped specimen which was reported by K. Hauffe *et al.* to be an electronic conductor [16] was also examined; the results are illustrated in Fig. 10 and Table 1. The colour of this material was black and the conductivities were fairly high at relatively low temperatures. The emf of the oxygen concentration cell using this specimen as the electrolyte was observed to be zero, indicating that the conduction in this substance was completely electronic as previously pointed out [16].

Conclusion

It can be concluded from the present experiments

that the sintered oxides of the system $\text{Bi}_2\text{O}_3\text{-SrO}$ are high oxide ion conductors in the composition of 20~40 mole% SrO, where the rhombohedral solid solution is formed. Furthermore, the sintered specimens of the system $\text{Bi}_2\text{O}_3\text{-CaO}$ and $\text{Bi}_2\text{O}_3\text{-La}_2\text{O}_3$ were also found to be oxide ion conductors, the ion transference numbers of which were greater than 0.9.

These materials are characterized by their high oxide ion conduction, the values of which are several times higher than those of the well-known stabilized zirconias at the same temperatures up to 800°C . Their disadvantage is that they are apt to be reduced and to have electronic conduction under relatively low partial pressures of oxygen.

References

- [1] T. H. Etsell and S. N. Flengas, *Chem. Reviews*, **70** (1970) 339.
- [2] C. Wagner, *Naturwiss.*, **31** (1943) 265.
- [3] F. Hund, *Z. Phys. Chem.*, **199** (1952) 142.
- [4] T. Takahashi, H. Iwahara and T. Ichimura, *Denki Kagaku*, **37** (1969) 857.
- [5] T. Takahashi and H. Iwahara, *Denki Kagaku*, **39** (1971) 400.
- [6] T. Takahashi and H. Iwahara, *Energy Conversion*, **11** (1971) 105.
- [7] L. G. Sillén and B. Aurivillius, *Z. Krist.*, **101** (1939) 483.
- [8] A. D. Neuimin, L. D. Yushina, Yu. M. Ovchinnikov and S. F. Palguyev, Trans. No. 4 of the Inst. Electrochem. Urals Acad. of Sciences 'Electrochem. of Molten and Solid Electrolytes', **2** (1964) 92.
- [9] C. Wagner, *Z. Phys. Chem.*, **21** (1933) 25.
- [10] C. N. R. Rao, G. V. Subba Rao and S. Ramdas, *J. Phys. Chem.*, **73** (1969) 672.
- [11] T. S. Zolyan and A. R. Regel, *Fiz. Tverd. Tela.*, **5** (1962) 2420.
- [12] M. G. Hapase and V. B. Tare, *Indian J. Pure Appl. Phys.*, **5** (1967) 401.
- [13] R. W. Christy, *J. Chem. Phys.*, **34** (1961) 114.
- [14] T. Takahashi and H. Iwahara, *Denki Kagaku*, **34** (1966) 254.
- [15] E. M. Levin and R. S. Roth, *J. Research Natl. Bur. Standards*, **68A** [2] (1964) 199.
- [16] K. Hauffe and H. Peters, *Z. Phys. Chem.*, **201** (1952) 121.